

Chapter 1: Basic Information	2
1.1 Before Use, please prepare:.....	2
1.1.1 SIM Card.....	2
1.1.2 APN	2
1.1.3 PIN.....	2
1.1.4 SMS Centre Number (SMSC).....	2
1.1.5 WCR	2
1 2 SJT-WCR Dimension L * W * H 125x110x27mm	2
Chapter 2: System Setup.....	3
2 1 SJT-WCR Connection to BL3-U Integrated controller.....	3
2 2 BL3-U Parameter Setup.....	3
2 3 WCR Parameter Setup	4
2.3.1 Basic Definition	4
2.3.2 Test.....	5
Chapter 3: Hand Operator Menu.....	6
3.1 Main Menu	6
3.2 Parameter Setup	7
3.2.1 Set Monitor Platform IP.....	7
3.2.2 Set Monitor Platform Port Number	7
3.2.3 BS Platform Sequence number	7
3.2.4 Save parameters	7
3.2.5 Return Factory Setting	7
3.2.6 Set monitor heart-beat interval.....	7
3.2.7 Set special function (not used)	8
3.2.8 Set SMS centre number (Optional).....	8
3.2.9 Set SMS alert mobile number. (Optional).....	8
3.2.10 Set System Tim	8
3.2.11 Set APN	8
3 3 Monitor Interface Check (Not used).....	8
3.3.1 Terminal Communication Check (Not used)	8
3.3.2 Running Status Monitor Not used	9
3.3.3 SIM card IMSI code	9
3.3.4 Software Information	9
3.3.5 Display heart beat interval.....	9
3.3.6 CAN Communication Status.....	9

1.1 Before Use, please prepare:

1.1.1 SIM Card

- ✧ 1 SIM card from local network provider
- ✧ Must have GPRS tariff (usage about 20MB-50MB per month)

1.1.2 APN

- ✧ An [Access Point Name \(APN\)](#) is the name of a gateway between a GPRS (or 3G, etc) mobile network and another computer network, frequently the public Internet;
- ✧ Please get the APN information from the local network provider;
- ✧ For more information on APN please visit: http://en.wikipedia.org/wiki/Access_Point_Name

1.1.3 PIN

- ✧ Every SIM card has a [Personal Identification Number \(PIN\)](#), normally include 4 digit;
- ✧ Please get the default PIN for the SIM card from the local network provider;
- ✧ Important: Put the SIM card in any cell phone and change the PIN to "2006"; Methods of changing PIN varies on different mobiles, for Iphone, please visit: <http://support.apple.com/kb/HT1316>

1.1.4 SMS Centre Number (SMSC)

- ✧ The SMSC is stored on your phone or SIM, and is used to forward your outgoing text messages to the network operator. If your phone suddenly loses the ability to send a text message - it could be a problem with the SMSC number stored in your phone.
- ✧ Check your mobile phone's "Message Settings" or "Message Options" entries, and look for "Message Centre" or "SMS Centre number". If you're having problems, try the phone's instruction book, or look for information online; If still in doubt, please ask the local network provider.

1.1.5 WCR

- ✧ Enter APN information in the WCR through hand operator (see chapter 3)
- ✧ Inform SIM card IMSI information to Bluelight technical department to build the monitor account on the platform (see chapter 3)
- ✧ Inform WCR BS Seq number to Bluelight technical department (see chapter 3)
- ✧ Input the SMSC in the WCR rTf1 0 0 1 76.944 203.9541C inyou3(u)5(3(ui0 1 35.45DC BTf6 9 Tf1 0 0 1 76.944 203.9 Tm0)JJEEMC /P PNCID

2.1 SJT-WCR Connection to BL3-U Integrated controller

- ✧ Must connect the CAN BUS to integrated controller COP/LOP CAN BUS port on J7 (J7-7 for CAN+, J7-8 CAN-);
- ✧ For 24V & GND, WCR can connect to control cabinet power switch 24V output & GND (this way the WCR and BL3-U has the common 24V input)

WCR Port Definition

	24V	J1-1	24V Power Input	Power	Power	DC24V/400mA		

2.3.2 Test

1. Make sure the connections are correct & power on the WCR

2. After WCR power on, please check all indicators:

- a) Power indicator on, if otherwise, please disconnect power and check cables;
- b) Network indicator on with flash (fast flash for searching network, slow flash for found network);
- c) During system initiation, Comm & Service indicator will first continue on for 5s, then they will flash for 20s, then system will be in working state.
- d) System Initiation indicator flash sequence:

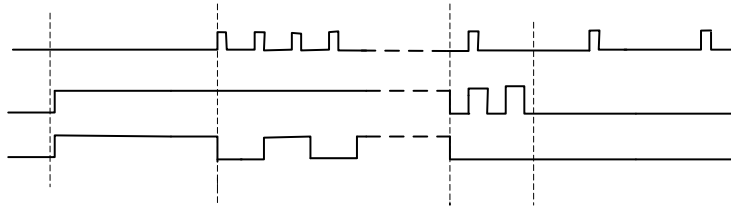

3. CAN BUS Test on BL3-U:

Check the BL3-U red LED, they should flash, and hand operator monitor screen should not have any CAN Comm error.

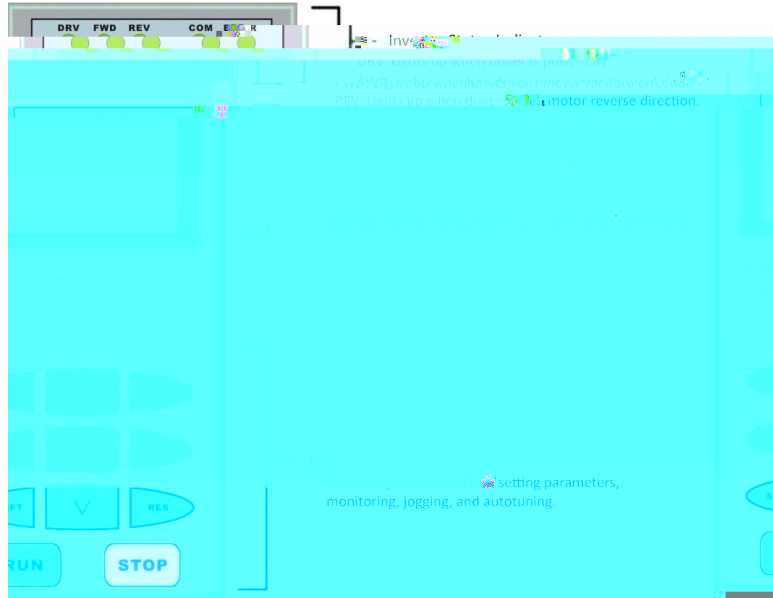

Menu	Return to main interface
Enter	Next level menu/Confirm change parameters
Esc	Cancel operation/Return to previous level menu
	Move right
Up or	1, Yes, ON
Down or	1, No, OFF

3.1 Main Menu

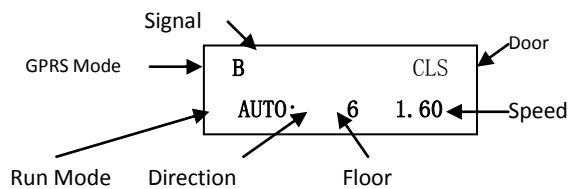

- ✧ GPRS Mode Number 0-9 System Initiation;
 b Connect to application platform;
 g Connect to upgrade platform;
 B Log in to monitoring platform;
- ✧ Signal: GPRS network status, 4 black box indicate max signal. The recommend signal condition should be no less than 2 box;
- ✧ Door condition: Door Close Door Open;
- ✧ Floor: Shown the elevator current floor;

- ◇ Run mode: "AUTO": Automatic; "INSP": Inspection mode; "LERN": System service; "CAN": Communication terminated;
- ◇ Direction: Run Up Run Down;
- ◇ Speed: Current elevator speed (Display in m/s).

3.2 Parameter Setup

Press "ENT" in the main menu to enter parameter setup menu

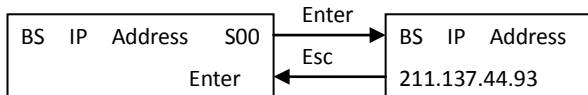

Check & set monitor platform IP, save parameter after setup.

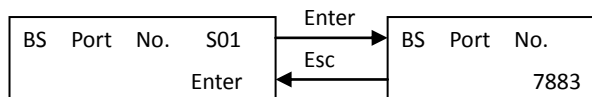

Check & set monitor platform port number, save parameter after setup.

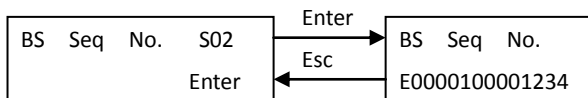

Check BS platform sequence number. During testing, please record this number together with SIM card IMSI number to build the elevator monitor account. If this number last 8 digits are all 0, it means the system has not assigned a sequence number to the WCR device. In normal cases after power on the WCR terminal for 2 minutes, the platform will automatic assign a sequence number to the WCR terminal.

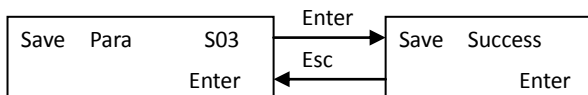

Please save parameters after setup, make sure all these parameters are valid after power down. Press "ENT" button in this interface to return parameter save menu.

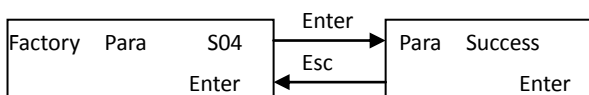

Remember to save parameters after reset to factory setting.

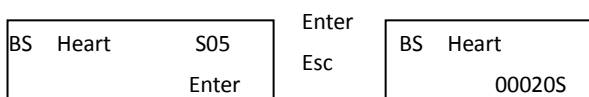

Check & set heart-beat interval between WCR terminal & Monitoring platform, unit in second.

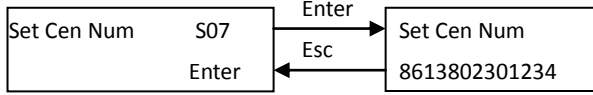
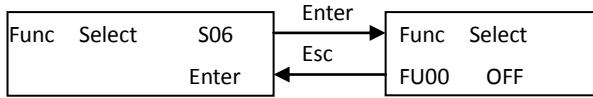

Check & set SMS centre number, WCR will re-read the SMS centre number after reboot.

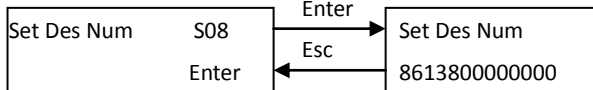

Check & set SMS alert mobile number. WCR will send SMS to this mobile for fault/alert on BL3-U.

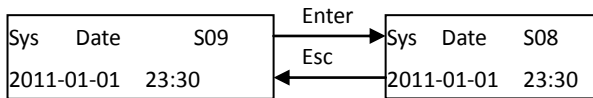

After connecting to monitor platform, the date/time information on WCR terminal will update automatically, user do not need to set.

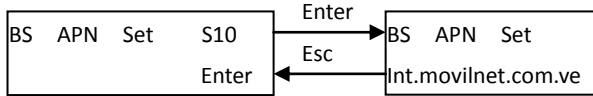

Check and set APN, user should first get the APN information from local network provider, then input in the WCR terminal with buttons. The input could only be letters and ".", save parameters after inputting the APN information.

3 3 Monitor Interface Check (Not used)

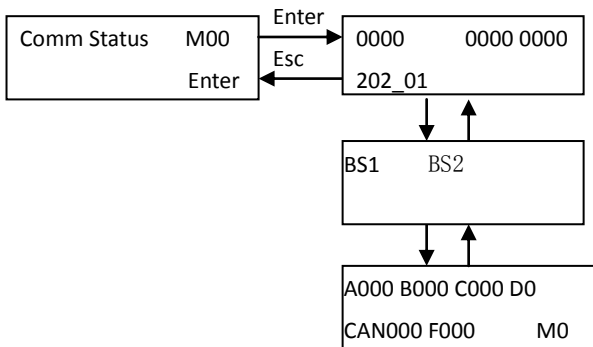



On the hand operator, press " " button several times to enter this interface. This IMSI code is the ONLY identification number for this WCR terminal. Please record this code and provide the information to Bluelight Technical department to build elevator monitor account.

On the hand operator, press " " button several times to enter this interface. User could check the WCR terminal software information. .

For example:

202_01 Software version

M:RC Chip Model

F:64 Flash Model

G:M10 GPRS Model

On the hand operator, press " " button several times to enter this interface.

On the hand operator, press " " button several times to enter this interface.

T000 CAN Communication send package number 000CAN Communication send error number

R000 CAN